

STERLING
ELECTRIC, INC.

3 Phase AC Induction Motors

INSTALLATION AND OPERATION MANUAL

August 21, 2015

Indianapolis, Indiana (800) 866-7973

e-mail: sales@sterlingelectric.com

www.sterlingelectric.com

STERLING
ELECTRIC, INC.

7973 Allison Avenue, Indianapolis, IN 46268

(800) 866-7973 FAX (317) 872-0907

INSTALLATION AND OPERATION OF STERLING 3-PHASE AC INDUCTION MOTORS

DANGER

ONLY QUALIFIED ELECTRICAL PERSONNEL FAMILIAR WITH THE CONSTRUCTION AND OPERATION OF THE EQUIPMENT AND THE HAZARDS INVOLVED SHOULD INSTALL, ADJUST, OPERATE, AND/OR SERVICE THIS EQUIPMENT. READ AND UNDERSTAND THIS MANUAL IN ITS ENTIRETY BEFORE PROCEEDING. FAILURE TO OBSERVE THIS CAUTION COULD RESULT IN SEVERE BODILY INJURY OR LOSS OF LIFE.

SELECTION INFORMATION

Buyer shall be solely responsible for determining the adequacy of the product for any and all uses to which buyer shall apply the product. The application by buyer shall not be subject to any implied warranty of fitness for a particular purpose. Information contained in this manual is considered correct at the time of publication and is subject to change without notice.

Read ALL instructions prior to operating unit. Improper maintenance or operation may cause injury to personnel or reducer failure.

SAFETY ALERT

WARNING: For safety, purchaser or user should provide protective guards over all shaft extensions and any moving apparatus mounted thereon. The user is responsible for checking all applicable safety codes in his area and providing suitable guards. Failure to do so may result in bodily injury and/or damage to equipment.

WARNING: Make certain that the power supply is disconnected before attempting to service or remove any components. Lock out the power supply and tag it to prevent unexpected application of power.

CAUTION: Test run unit to verify operation. If the unit tested is a prototype, that unit must be of current production.

WARNING: For motors to be used in hazardous locations, check National Electric Code, NEMA, and UL (Underwriters Laboratory) standards to make sure that explosion-proof motors are not required. Note that UL labeling (certification) is required in some hazardous locations.

CAUTION: Rolled Steel motors and Stainless Steel motors are designed to run at elevated temperatures. Avoid physical contact. Use gloves and/ or other protective clothing or gear when working in the proximity of these motors while they are in operation.

IMPORTANT INFORMATION

In the event of the resale of any of the goods, in whatever form, Resellers/Buyers will include the following language in a conspicuous place and in a conspicuous manner in a written agreement covering such sale:

The manufacturer makes no warranty or representations, expressed or implied, by operation of law or otherwise, as to the merchantability or fitness for a particular purpose of the good sold hereunder. Buyer acknowledges that it alone has determined that the goods purchased hereunder will suitably meet the requirements of their intended use. In no event will manufacturer be liable for consequential, incidental or other damages.

Resellers/Buyers agree to also include this entire document including the warnings above in a conspicuous place and in a conspicuous manner in writing to instruct users on the safe usage of the product.

This instruction manual should be read together with all other printed information such as catalogs, supplied by Sterling Electric.

RECEIVING

1. Check nameplate data.
2. Check whether any damage has occurred during transportation. If there is evidence of rough handling or potential damage in shipment, file a claim immediately with the carrier. Notify your Sterling Electric sales representative.
3. Turn motor shaft by hand to check that it turns freely.

NOTE: Large motors may have a shaft locking device to aid in the protection of the bearings during shipment. This locking device needs to be removed before the motor is put into service.

INSTALLATION

Location and Mounting Position

- A. The location for installing motors should be accessible and allow routine inspection, cleaning, and maintenance.
- B. ODP (Open Drip Proof) motors are designed for installation in a well-ventilated area where the atmosphere is reasonably free of dirt and moisture.
- C. TEFC (Totally Enclosed Fan Cooled) or TENV (Totally Enclosed Non Ventilated) motors may be installed where dirt, moisture and corrosion are present, or in outdoor locations. For locations where motors will be exposed to washdown or severe weather, washdown duty motors are recommended.

WARNING: For locations considered hazardous or flammable, check National Electric Code, NEMA, and UL standards to make sure that explosion-proof motors are not required. Note the UL labeling (certification) is required in some hazardous locations.

- D. All general purpose and washdown duty cast iron motors and general purpose rolled steel motors are configured for horizontal foot mounting (F-1 or F-2) as standard. For all other mounting positions including vertical, ceiling, or wall mount, consult factory.
- E. All stainless steel and rolled steel washdown duty motors can be mounted in any position as long as the condensation drain plugs are removed in the proper location and the supplied T-drains are installed. Failure to do so will void the warranty. Please refer to the condensation drain instructions supplied with the motor.

Environment

A. Temperature

- 1. For standard motors, ambient operating temperature is normally within the range of -15 to 40°C (5 to 104°F).
- 2. In case of excessive ambient temperature, or excessive heat, protective measures, such as forced cooling or heat insulating should be applied or the load should be reduced.
- 3. If the ambient temperature is too low, space heaters may need to be added to the motor.

B. Ventilation

- 1. All motors will require the free circulation air whether the enclosure is ODP, TEFC, or TENV. If the motor is installed in poorly ventilated area, steps may have to be taken to guard the motor against over-heating which may include de-rating the motor or reducing the load.
- 2. For ODP motors with internal fans and TEFC motors with external fans, a clearance of at least (8) inches from ventilation ports is required around motor to assure proper airflow.

C. Humidity

- 1. If the motor is installed outdoors or in very damp or wet environments, steps may have to be taken to guard the motor against excessive moisture or a washdown duty motor should be used.

D. Dust

- 1. **ODP Enclosure**
A large accumulation of dust on windings and cooling ducts will result in over-heated windings leading to insulation breakdown. In severe cases, dust accumulated on the rotor, not evenly distributed, can cause vibration. If dust particles get into the bearings, the lubricant should be changed as soon as possible to prevent damage.
- 2. **TEFC Enclosure**
A large accumulation of dust on the frame, fins, and other surfaces will greatly reduce heat dissipation. If the dust accumulated on cooling fans or transmission device is not evenly distributed poor balance and vibration can occur.

3. TENV Enclosure
A large accumulation of dust on the frame and other surfaces will greatly reduce heat dissipation.

E. Gases and Steam

1. If corrosive, flammable, or other chemical gases, or steam exist in the environment, motors of explosion-proof type or corrosion protective motors should be chosen; particular attention should be placed on motor selection, when flammable gases, dust, or steam, which are all liable to fire hazard, exist.

WARNING: For hazardous locations, check National Electric Code, NEMA, and UL standards to make sure the explosion-proof motors selected are satisfactory. Note UL labeling (certification) is required in some hazardous locations.

Foundation

- A. The ground footing or foundation on which motors are installed must be hard and stable and not susceptible to vibration from surrounding equipment. If not, vibration may become excessive, especially when coupled to machines such as crushers and reciprocating compressors. Vibration of a large amplitude while the motor is running can bring about the following failures:
 1. The service life of bearings may be reduced.
 2. Parts may come loose or become displaced.
 3. Cooling fans or other parts on rotor may fail due to material fatigue.
 4. The insulation on the windings could be damaged.
- B. Severe vibration from the environment may induce vibration on motors causing some damage. Depression on roller bearings can occur during idle periods (when the motors are not running).

Power Supply

- A. Nameplate voltage and frequency must agree with power supply. Motor will operate satisfactorily on line voltage within 10% of nameplate value or frequency within 5%. The combined variation is not to exceed 10%. 230 volt motors can be used on 208 volt network systems, but with slightly modified performance characteristics.
- B. Dual voltage motors can be connected for the desired voltage by following the connection diagram on the nameplate. For motors capable of alternate starting methods such as part winding start and wye start-delta run, the proper connections are located on a connection diagram inside the conduit box cover or consult factory.
- C. Wiring of motor and motor control, overload protection and grounding should be in accordance with the National Electric Code and/or local building codes.

- D. The following are the connection diagrams for STANDARD 3-phase general purpose 9-lead and 12-lead dual voltage motors. For all other connections such as two speed motors, 1-phase motors, alternate starting methods, etc., consult factory.

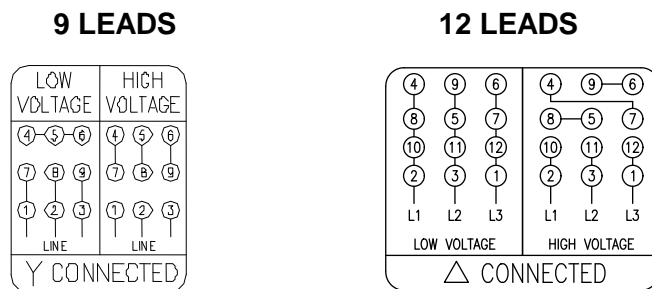

Thermal Protection

The motor nameplate will indicate whether the motor is thermally protected. These are Normally Closed (NC) “Klixons” that open when a predetermined temperature is reached breaking continuity. Thermal protection leads are labeled **P1** and **P2** and are to be connected in series with the motor magnetic starter holding coil or magnetic starter assembly. For inverter duty motors used with VFD (Variable Frequency Drive) controllers, connect to interlock circuitry so that the contact will open to stop the controller in the event that the motor overheats.

Altitude

If the motor location is more than 3300 feet above sea level, the operating temperature of the motor will be 5 to 10°C higher. The motor may require de-rating to allow for this additional heating. Consult factory.

Alignment Procedures

Since poor alignment will bring about vibration and early bearing failure it is essential to be accurate when doing alignment of the motor to the driven equipment. The following steps should be taken to obtain proper alignment to the driven equipment.

1. Use a level instrument to adjust the level mounting plate or surface to which the flange of the motor will mount.
2. Check the (up and down) endplay of the shaft of driven machine.
3. Mount the motor on the mounting plate and/or driven equipment. Install mounting bolts but do not tighten. Mounting hardware should be grade 5 or higher.
4. Check angular alignment by using a feeler gauge between coupling hubs at four points, 90 degrees apart. Position the motor to obtain best possible alignment and correct coupling hub separation. Consult factory, equipment supplier, or coupling manufacturer for proper values.

5. Check the offset alignment between the two shafts. Use a dial indicator mounting on one hub (motor side, for example), with the dial indicator button contacting the alignment surface of the opposite hub. Rotate the opposite shaft slowly by hand and take a reading on at least four equally spaced points. Move motor until the indicator movement does not exceed 0.002 in. Transfer indicator to opposite hub and recheck. Recheck angular alignment as described above.

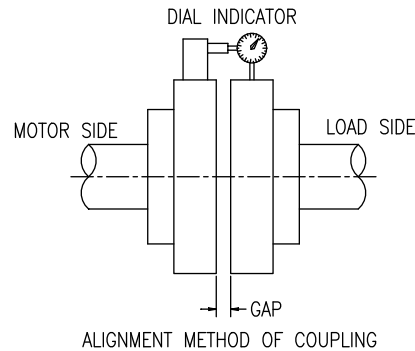

6. After each corrective adjustment is made, connect the couplings and tighten the motor and mounting plate bolts. Recheck the alignment and correct if necessary.

Belts

- A. V-Belt Sheave Pitch Diameters should not be less than the NEMA recommended values. Refer to NEMA MG1-14.41.
- B. Tighten belts only enough to prevent belt slippage. Belt speed should not exceed 5000 feet per minute.

START UP

1. If the motor has become damp or has been in storage for a prolonged period of time, measure the insulation resistance of the stator winding. For motors rated 600V and below the minimum resistance should not be less than 1 megaohm. If the insulation resistance measures less than the desired value, it may be necessary to dry the windings, especially if the motor has been stored in a damp location. In drying, DO NOT exceed 90°C (194°F).
2. Disconnect load and start motor. Check direction of rotation. Interchange any two line leads to reverse rotation on 3-phase motors.
3. Connect the motor to load referring to procedures above for mounting and alignment. The motor should start up quickly and run smoothly. If not, shut power off at once. Recheck the assembly including all connections before restarting.
4. Operate under load for at least one hour. Observe whether any unusual noise or heating has developed and check operating current against nameplate data.
5. If excessive vibration is noted, check for loose mounting bolts, too flexible of a motor support structure, or transmitted vibration from adjacent machinery. Recheck the coupling alignment between the motor and the driven equipment.

MAINTENANCE

A. Inspection

Inspect motor at regular intervals.

Keep motor clean and ventilating openings clear of any obstructions. Double check the mounting bolts and couplings to ensure that they are tight and properly adjusted.

Check belt tension and adjust of necessary.

B. Lubrication

Motors in storage longer than 2 years should have the bearings inspected and/or replaced before putting the motor into service.

Motors with pre-lubricated double sealed bearings (bearing suffix LL, VV, or UU) or double shielded bearings (bearing suffix ZZ) do not need to be re-lubricated and are considered lubricated for life. However, it is recommend changing bearings at times shown, but if not changeable, you can re-lubricate by removing seal plate, cleaning and refilling the bearing and bracket cavity with the recommended grease.

Motors with re-greasable bearings have sufficient lubrication from the factory for storage up to 2 years. However, bearings should be re-lubricated when the motor is initially put into service and at the intervals shown below thereafter, or whenever the motor has been inoperable for more than 2 months.

FREQUENCY OF RELUBRICATION

MOTOR RPM	FRAME VS. HP	TYPE OF SERVICE	
		STANDARD 8 HR/DAY	HEAVY DUTY 24 HR/DAY
3600	143T - 286TS 1.5 - 30	*	*
	324TS - 445TS 40 - 150	6 MONTHS	2 MONTHS
1800	143T - 256T 1 - 20	*	*
	284T - 326T 25 - 50	4 YEARS	18 MONTHS
	364T-445T 60 - 150	9 MONTHS	3 MONTHS
1200	143T - 256T .75 - 10	*	*
	284T - 326T 15 - 30	4 YEARS	18 MONTHS
	364T - 445T 40 - 125	1 YEAR	4 MONTHS

* Motors of this size normally do not have bearings that can be re-lubricated. These bearings should be replaced at least every 5 years for 8 hr/day service, or every 2 years for 24 hr/day service.

- C. Instructions for lubricating
Motors with re-greasable type bearings are to be lubricated using the following steps. See the figure below for reference.

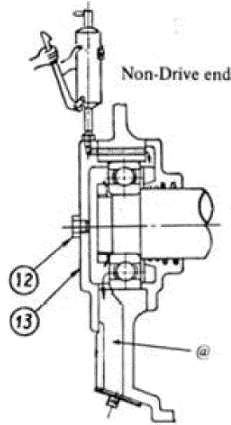

Figure 8

@ Storage for discharged grease

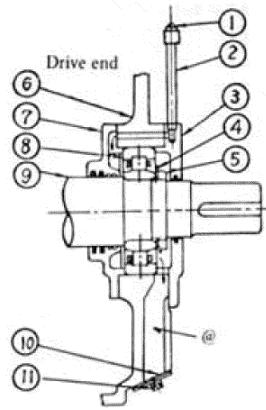

Figure 9

@ Storage for discharged grease

Item Number	Description	Item Number	Description
1	Grease Fitting	8	Roller Bearing
2	Grease Fitting Extension Pipe	9	Motor Shaft
3	Outer Bearing Cap	10	Grease Relief Cover Plate
4	Bearing Lock Washer	11	Cover Plate Thumb Screw
5	Bearing Lock Nut	12	Bolt
6	Motor End Bracket	13	Outer Bearing Cap
7	Inner Bearing Cap		

1. Remove plastic cap covering grease fitting on both end brackets.
2. Remove pipe plug or cover plate opposite grease fitting for grease relief.
3. Be sure fittings are clean and free from dirt.
4. Using a low-pressure grease gun, pump in the recommended grease until new grease appears at the grease relief hole.
5. After relubricating, allow motor to run for 10 minutes to purge any excess grease before replacing any pipe plugs or cover plates in the end brackets.
6. Remove discharged grease from relief area, clean area thoroughly, and replace pipe plugs or cover plate.

D. Recommended Greases

Unless special grease is specified on the motor nameplate, standard Sterling Electric motors use lithium based NLGI grade #3 bearing grease. Use the following compatible grease: Shell Alvania R3, BP Energrease LS3, Castrol Spherol MP3, Esso Beacon 3, Gulf Gulfcrown Grease No.3, Texaco Multifak Premium 3, Mobil Mobilux EP3, Kluber Centoplex 3.

E. Lubrication Amounts

The following replenishment amounts are for motors with provisions for re-greasable bearings. Typically smaller motors (250 and below) do not have this feature.

NEMA Frame Size	Volume (fl-oz)
280T	1.13
320T	1.13
360T	1.87
400T	1.87
440T	1.87

CAUTION: The amount of grease in the bearings is critical. Too little grease or too much grease will cause excessive wear, noise, and elevated running temperatures leading to premature bearing failure and possible permanent motor damage. Refer to motor nameplate or table above for amount and type of grease, or consult factory.

REPLACEMENT PARTS

- A. Sterling Electric motors use commercially available bearings and seals (where appropriate) that can usually be sourced locally. For all other items or items that are not readily available, consult factory.
- B. When ordering replacement parts, include the unit model number, serial number, item number and description (from parts list), and the quantity required.

WARRANTY

Generally, Sterling Electric will correct by repair or replacement any defect in material and workmanship when properly used for a period of one year after installation, or 18 months after shipment, whichever one comes first. Sterling Electric is not responsible for apparatus returned without proper authorization and identification, improper handling or storage, misapplication of the motor or the driven equipment or device. Sterling Electric, as a motor manufacturer, sells quality motors that are warranted to perform at a given load condition with performance characteristics in accordance with NEMA Standards. Sterling Electric is not responsible for the application, installation, or proper maintenance of the motor. Proper application, and whether a given motor is suited for a given application, is the responsibility of the purchaser and/or user of the motor. Refer to the complete Conditions of Sale and Warranty available from any Sterling Electric authorized distributor or factory representative.

TROUBLE SHOOTER'S GUIDE BASED ON SYMPTOMS

SYMPTOMS	CAUSE	RESULT	REMEDY
1. Motor does not start.	a. Incorrectly connected.	a. Burnout	a. Connect correctly per diagram on motor.
	b. Incorrect power supply.	b. Burnout	b. Use only with correct rated power supply.
	c. Fuse out, loose or open connection.	c. Burnout	c. Correct open circuit condition.
	d. Open control circuit.	d. None	d. Correct open circuit condition.
	e. Rotating parts of motor may be jammed mechanically.	e. Burnout	e. Check and correct: 1. Bent shaft 2. Broken housing 3. Damaged bearing 4. Jammed or broken fan 5. Foreign material in motor
	f. Driven machine may be jammed.	f. Burnout	f. Correct jammed condition.
	g. No power supply.	g. None	g. Check voltage at motor and work back to power supply.
2. Motor starts, but does not come up to speed.	a. Same as 1-a, b, c above.		
	b. Overload	b. Burnout	b. Reduce load to bring current to rated limit. Use proper fuses and overload protection.
3. Motor noisy electrically	a. Same as 1-a, b, c above.		
SYMPTOMS	CAUSE	RESULT	REMEDY
4. Motor runs hot. Exceeds rating.	a. Same as 1-a, b, c above.		
	b. Overload	b. Burnout	b. Reduce load.
	c. Impaired ventilation.	c. Burnout	c. Remove obstruction.
	d. Frequent start or stop.	d. Burnout	d. 1. Reduce number of starts or reversals. 2. Secure proper motor for this duty.
	e. Imbalance in voltage or frequency of power supply.	e. Burnout	e. Check and correct power supply.
5. Motor noisy mechanically	a. Misalignment of coupling or sprocket.	a. Bearing failure, broken shaft, burnout due to rotor drag.	a. Correct misalignment.
	b. Mechanical unbalance of rotating parts.	b. Same as 5-a	b. Find unbalanced part, then rebalance.
	c. Lack of or improper lubricant.	c. Bearing failure	c. Use correct lubricant, and replace parts as necessary.
	d. Foreign material in lubricant.	d. Same as 5-c	d. Clean out or replace bearing.
	e. Overload	e. Same as 5-c	e. Remove overload condition. Replace damaged parts.
	f. Shock load.	f. Same as 5-c	f. Correct causes and replace damaged parts.
	g. Mounting acts as amplifier of normal noise.	g. Annoying	g. Isolate motor from base.
	h. Rotor dragging due to worn bearings, shaft or bracket	h. Burnout	h. Replace bearings, shaft or bracket as needed.
6. Bearing failure	a. Same as 5-a, b, c, d, e above.	a. Burnout, damaged shaft or housing	a. Replace bearings and follow 5-a, b, c, d, e above.
	b. Entry of water or foreign material into bearing housing.	b. Same as 6-a above	b. Replace bearings and shield against entry of foreign material (water, dust, etc.) Use proper motor.

TYPICAL BURNOUT PATTERNS

SYMPTOM	CAUSED BY	APPEARANCE
1. Shorted coil	a. Moisture, chemicals, foreign material in motor, damage winding.	a. Black or burned coil with remainder of winding good.
2. 100% Burnout	a. Overload.	a. Burned equally all around winding.
	b. Stalled.	b. Burned equally all around winding.
	c. Impaired ventilation.	c. Burned equally all around winding.
	d. Frequent reversal or starting.	d. Burned equally all around winding.
	e. Incorrect power.	e. Burned equally all around winding.
3. Single phase condition.	a. Open circuit in one line. The most common causes are loose connection, one fuse out, loose contact in switch or contactor.	<p>a. If 1800 RPM motor-four equally burned groups at 90° intervals.</p> <p>b. If 1200 RPM motor-six equally burned groups at 60° intervals.</p> <p>c. If 3600 RPM motor-two equally burned groups at 180° apart.</p> <p>NOTE: If WYE connected each burned group will consist of two adjacent phase groups. If DELTA connected each burned group will consist of one phase group.</p>
4. Other	a. Improper connection.	a. Irregular burned groups or spot burns.
	b. Ground	b. Badly damaged burn spot.

PARTS LIST ** TOTALLY ENCLOSED FAN COOLED (T.E.F.C.)

ITEM	DESCRIPTION
1	Wound Stator w/Frame
2	Rotor Assembly
3	Rotor Core
4	Shaft
5	Bracket, Drive End
6	Bracket, Opp. Drive End
7	Bearing, Drive End
8	Bearing, Opp. Drive End

ITEM	DESCRIPTION
9	Lead Seal
10	Wave Washer 56 - 320T
	Bearing Shim 360T - 440T
11	Slinger
12	Outside Fan
13	Fan Cover
14	Conduit Box Assembly
15	Lifting Eye

BEARINGS

FRAME	T-SERIES 7	T-SERIES 8	E-SERIES 7	E-SERIES 8	N,R-SERIES 7	N,R-SERIES 8	S,X,D-SERIES 7	S,X,D-SERIES 8
56					6205ZZ*	6204ZZ	6205LL	6204LL
140T	6205LL	6205LL	6205ZZ	6205ZZ			6205LL	6204LL
180T	6206LL	6206LL	6207ZZ	6206ZZ			6306LL	6206LL**
210T	6208LL	6208LL	6308ZZ	6208ZZ			6308LL	6306LL
250T	6309LL	6309LL	6310ZZ	6208ZZ			6309LL	6309LL
280T	6311CLL	6311CLL	6310ZZ	6210ZZ			6311LL	6311LL
280TS	6311C3LL	6311C3LL	6310C3	6210C3			6311C3LL	6311C3LL
320T	6312C3	6312C3	6312ZZ	6212ZZ				
320TS	6312C3	6312C3	6312C3	6212C3				
360T	6314	6314	NU215	6312				
360TS	6314C3	6314C3	6312C3	6312C3				
400T	6316	6316	NU218	6313				
400TS	6316C3	6316C3	6313C3	6313C3				
440T	NU316	6316	NU220	6315				
440TS	6316C3	6316C3	6313C3	6313C3				

* N-Series footed models with non-C-face output end have 6204ZZ bearings on both ends.

** 2P (3600RPM) 180T X-Series stainless steel motors and D-Series rolled steel motors have 6305LL bearing at position 8.

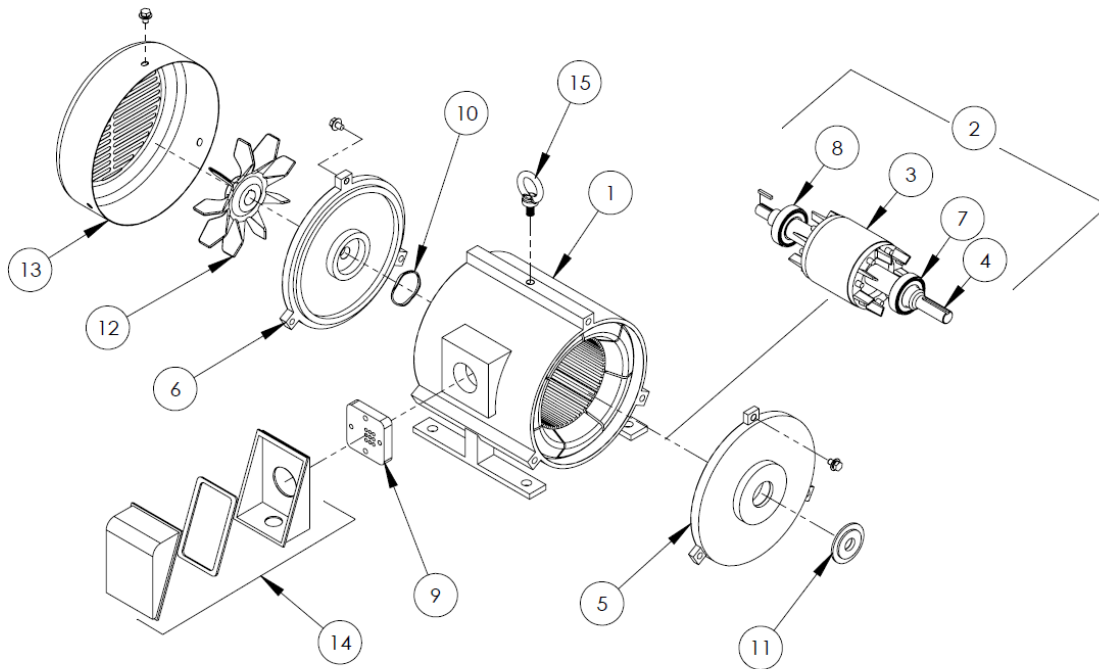

PARTS LIST ** OPEN DRIP PROOF (O.D.P)

ITEM	DESCRIPTION
1	Wound Stator w/Frame
2	Rotor Assembly
3	Rotor Core
4	Shaft
5	Bracket, Drive End
6	Bracket, Opp. Drive End
7	Bearing, Drive End
8	Bearing, Opp. Drive End

ITEM	DESCRIPTION
9	Lead Seal
10	Wave Washer 56 - 320T Bearing Shim 360T - 440T
11	Slinger
14	Conduit Box Assembly
15	Lifting Eye
16	Air Deflector

BEARINGS

FRAME	E-SERIES 7	E-SERIES 8	J-SERIES 7	J-SERIES 8	C,P-SERIES 7	C,P-SERIES 8		
56					6204ZZ	6203ZZ		
140T			6205ZZ	6205ZZ				
180T			6306ZZ	6206ZZ				
210T	6308ZZ	6208ZZ	6308ZZ	6208ZZ				
250T	6309ZZ	6208ZZ	6309ZZ	6208ZZ				
280T	6312ZZ	6211ZZ	6312ZZ	6211ZZ				
280TS	6311C3	6311C3	6311C3	6311C3				
320T	6313	6312	6313	6312				
320TS	6312C3	6312C3	6312C3	6312C3				
360T	6314	6314	6314	6314				
360TS	6313C3	6313C3	6313C3	6313C3				
400T	6317	6317	6317	6317				
400TS	6313C3	6313C3	6313C3	6313C3				
440T	NU318	6318	NU318	6318				
440TS	6313C3	6313C3	6313C3	6313C3				

