

# **2000HG<sup>®</sup>**

---

## **HELICAL GEAR RATIO MULTIPLIER**

### **INSTALLATION AND MAINTENANCE MANUAL**

June 16, 2008

Indianapolis, Indiana (800) 866-7973  
Hamilton, Ontario (800) 809-0330

e-mail: [sales@sterlingelectric.com](mailto:sales@sterlingelectric.com)  
[www.sterlingelectric.com](http://www.sterlingelectric.com)

## 2004HG HELICAL GEAR RATIO MULTIPLIER INSTRUCTION MANUAL

### SELECTION INFORMATION

Read ALL instructions prior to operating unit. Improper maintenance or operation may cause injury to personnel or reducer failure.

Written authorization from Sterling Electric is required to operate or use this unit in man lift or people moving devices.

Check to make certain application does not exceed the allowable load capacities published in the current catalog.

Buyer shall be solely responsible for determining the adequacy of the product for any and all uses to which buyer shall apply the product. The application by buyer shall not be subject to any implied warranty of fitness for a particular purpose. Information contained in this manual is considered correct at the time of publication and is subject to change without notice.

### SAFETY ALERT

**WARNING:** For safety, purchaser or user should provide protective guards over all shaft extensions and any moving apparatus mounted thereon. The user is responsible for checking all applicable safety codes in his area and providing suitable guards. Failure to do so may result in bodily injury and/or damage to equipment.

**WARNING:** Hot oil or gear units can cause severe burns. Use extreme care when removing lubrication plugs and vents.

**WARNING:** Make certain that the power supply is disconnected before attempting to service or remove any components. Lock out the power supply and tag it to prevent unexpected application of power.

**WARNING:** Any brakes that are used in conjunction with this unit must be sized or positioned in such a way as to not subject the unit to loads beyond the catalog rating.

**CAUTION:** Test run unit to verify operation. If the unit tested is a prototype, that unit must be of current production.

**CAUTION:** If the unit cannot be located in a clear and dry area with access to adequate cooling air supply, then precautions must be taken to avoid the ingestion of contaminants such as water and the reduction in cooling ability due to exterior contaminants. Units located in confined spaces may require forced air-cooling.

## IMPORTANT INFORMATION

In the event of the resale of any of the goods, in whatever form, Resellers/Buyers will include the following language in a conspicuous place and in a conspicuous manner in a written agreement covering such sale:

*The manufacturer makes no warranty or representations, expressed or implied, by operation of law or otherwise, as to the merchantability or fitness for a particular purpose of the good sold hereunder. Buyer acknowledges that it alone has determined that the goods purchased hereunder will suitably meet the requirements of their intended use. In no event will manufacturer be liable for consequential, incidental or other damages.*

Resellers/Buyers agree to also include this entire document including the warnings above in a conspicuous place and in a conspicuous manner in writing to instruct users on the safe usage of the product.

This instruction manual should be read together with all other printed information such as catalogs, supplied by Sterling Electric.

## GENERAL OPERATION

1. Run the motor, which drives the unit, and check the direction of unit output rotation. Consult motor nameplates for instructions to reverse the direction of rotation.
2. Attaching the load: On direct-coupled installations, check shaft and coupling alignment between unit and loading mechanism. On chain/sprocket and belt/pulley installation, locate the sprocket or pulley as close to the oil seal as possible to minimize overhung load. Check to verify that the overhung load does not exceed specifications published in the catalog.
3. High momentum loads: If coasting to a stop is undesirable, a braking mechanism should be provided to the unit output or the driven mechanism.

**CAUTION:** The system of connected rotating parts must be free from critical speed, torsional or other type vibration, no matter how induced. The responsibility for this system analysis lies with the purchaser of the speed reducer.

## INSTALLATION

1. Mount the unit using grade 5 or higher fasteners.
2. For shipment, pipe plugs are installed in the unit and a vent plug is packed separately. After mounting the unit in position, remove the appropriate pipe plug and install the vent plug in the location shown in the chart under **LUBRICATION**. On double reduction units both the primary and the secondary must be vented. Failure to vent the unit can cause premature seal wear or loss of seal and oil. These conditions are not covered by warranty. Check for correct oil level. Contact the factory for level and vent recommendations on non-standard mounting positions.

**CAUTION:** Do not operate the unit without making sure it contains the correct amount of oil. Do not overfill or underfill with oil, or injury to personnel, reducer or other equipment may result.

**CAUTION:** A unit cannot be used as an integral part of a machine superstructure which would impose additional loads on the unit other than those imposed by the torque being transmitted either through a shaft-mounted arrangement, and any shaft mounted power transmitting device. (e.g. sprockets, pulleys, couplings)

**CAUTION:** For safe operation and to maintain the unit warranty, when changing a factory installed fastener for any reason, it becomes the responsibility of the person making the change to properly account for fastener grade, thread engagement, load, tightening torque and the means of torque retention.

## LUBRICATION

All standard helical ratio multipliers ordered from the factory are shipped with standard compounded lubricant and is good for ambient temperature ranges of 30° F to 104° F. Double reduction units have separate oil sumps and must be filled and checked independently. Use of synthetics can cause problems if they are not compatible with the seals or conventional lubes they replace. **Prior to startup, verify that the oil is at the level shown on the drawing below.** If the ambient temperature will be outside the range for the lubricant installed at the factory, drain and refill the reducer with the proper viscosity lubricant prior to use.

### VENT PLUG LOCATION

Before putting the unit into operation, substitute the vent plug for the solid plug at the position desired. Arrows indicate the recommended vent plug locations.

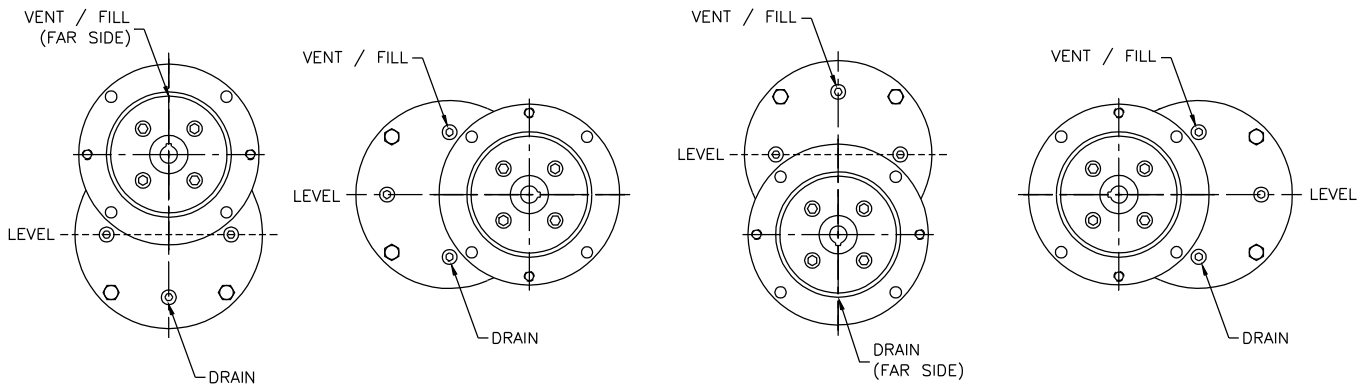

### OIL & WEIGHT SPECIFICATIONS

<b>Oil Type</b>	AGMA #4 SAE 40 Weight ISO 150
<b>Oil Capacity</b>	Size 1 6 fl oz Size 2 14 fl oz Size 3 14 fl oz

**Change Intervals:** Standard compounded lubricants should be changed every six months or 2500 operating hours, whichever comes first. Synthetic lubricants should be changed every two years or 6000 hours, whichever comes first.

**CAUTION:** Oil should be changed more often if the unit is used in a severe environment. (i.e. dusty, humid)

**CAUTION:** In the Food and Drug Industry (including animal food), consult the lubrication supplier for recommendation of lubricants which are acceptable to the Food and Drug Administration and/or other authoritative bodies having jurisdiction.

### **MAINTENANCE**

Your Sterling Electric unit has been tested and adjusted at the factory. Dismantling or replacement of components must be done by Sterling Electric to maintain the warranty.

Frequently check the oil level of the unit. If oil level is low, (refer to the vent and level position chart) add proper lubrication through the filler plug until it comes out the oil level plug.

Inspect vent plug often to insure it is clean and operating.

**CAUTION:** Mounting bolts should be routinely checked to ensure that the unit is firmly anchored for proper operation.

### **CLASS OF SERVICE**

All capacity ratings are based on American Gear Manufacturers Association (AGMA) Standards. Load conditions must be within cataloged ratings published in the current Sterling Electric Catalog (available upon request).

### **LONG-TERM STORAGE (6 MONTHS UP)**

Units must be stored indoors, in a dry, warm temperature.

Completely fill the unit with oil.

Rotate the input shaft so that the output shaft rotates at least one revolution per month.

Completely cover the input and output shaft with grease.

At the time of start up, drain the storage oil, install the breather, and fill to the proper oil level with correct lubricant for the operating condition.

### **WARRANTY (LIMITED)**

The warranty will cover all of the parts in the gearmotor or reducer unit for 12 months from the date of shipment.

The warranty is only for parts and labor. In no event shall our liability exceed the original price of the unit, nor does it cover cost of on site repair, installation, or freight.

Contact the service department for a complete explanation as to the full warranty policies and conditions of sale.

All dimensions designs and specifications are subject to change without notice

## SEAL AND BEARING SIZES

### Input Bearing

Unit Size	Bearing Part Number and Size				
	Series	OD (mm)	ID (mm)	Width (mm)	Sterling P/N
<b>1 (Quill Side)</b>	6005	47	25	12	400-0541-9
<b>1</b>	6200	30	10	9	400-0542-8
<b>2</b>	6204	47	20	14	400-0005-4
<b>3</b>	6204	47	20	14	400-0005-4

### ODE Output Bearing

Unit Size	Bearing Part Number and Size				
	Series	OD (mm)	ID (mm)	Width (mm)	Sterling P/N
<b>1</b>	6002	32	15	9	400-0543-7
<b>2</b>	6205	52	25	15	400-0006-2
<b>3</b>	6205	52	25	15	400-0006-2

### DE Output Bearings

Unit Size	Bearing Part Number and Size				
	Series	OD (mm)	ID (mm)	Width (mm)	Sterling P/N
<b>1</b>	6004	42	20	12	400-0544-6
<b>2</b>	6205	52	25	15	400-0006-2
<b>3 (180TC Output)</b>	6206	62	30	16	400-0008-9
<b>3 (210TC Output)</b>	6007	62	35	14	400-0367-3

### Input Seal

Unit Size	Bearing Part Number and Size			
	Shaft (mm)	Bore (mm)	Width (mm)	Sterling P/N
<b>1</b>	25	45	7	404-0372-8
<b>2</b>	35	45	7	404-0331-9
<b>3</b>	40	60	7	404-0352-8

### Output Seal

Unit Size	Bearing Part Number and Size			
	Shaft (mm)	Bore (mm)	Width (mm)	Sterling P/N
<b>1</b>	20	35	7	404-0286-4
<b>2</b>	25	40	7	404-0288-2
<b>3 (180TC Output)</b>	30	50	8	404-0291-9
<b>3 (210TC Output)</b>	35	50	8	404-0292-8

### Parts List

Item No.	Description	Qty	Item No.	Description	Qty
1	Gear Case Housing	1	13	Input Oil Seal	1
2	Gear Case Cover	1	14	NPT Plug	4
3	Quill Style Input Flange	1	15	ODE Output Bearing	1
4	Seal End Plug	1	16	Key	1
5	Retaining Ring (Shaft)	1	17	Output Shaft	1
6	Gasket	1	18	Gear	1
7	Input Bearing	1	19	DE Output Bearing	1
8	Retaining Ring (Housing)	1	20	Dowel Pin	2
9	Quill Input Shaft with Pinion	1	21	Output Oil Seal	1
10	Hex Head Bolt	5	22	Output Key	1
11	Hex Head Bolt (Motor Mounting)	4	23	Long Socket Head Cap Screw	2
12	Socket Head Cap Screw	4	24	Quill Side Input Bearing	1

**Notes:**

1. Item #23 required on Size 1 and 3 Ratio Multiplier only.
2. Item #24 required on Size 1 Ratio Multiplier only.

### SIZE 1 PARTS

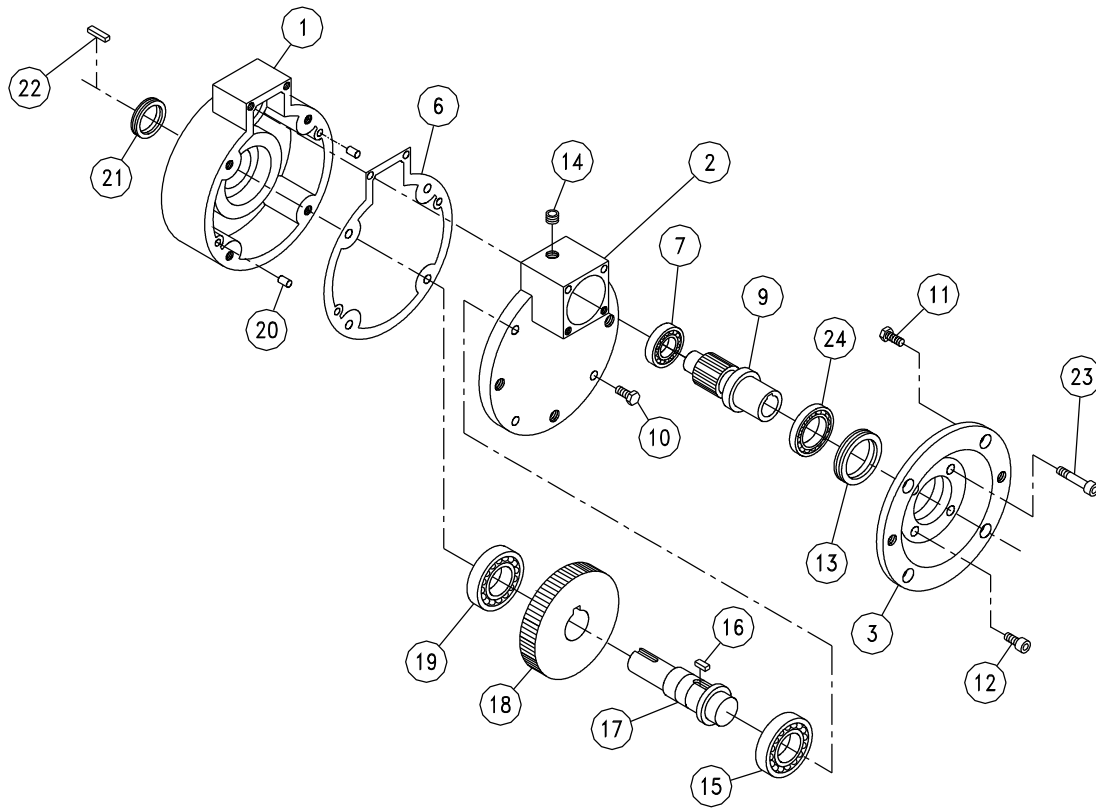

### SIZE 2 PARTS

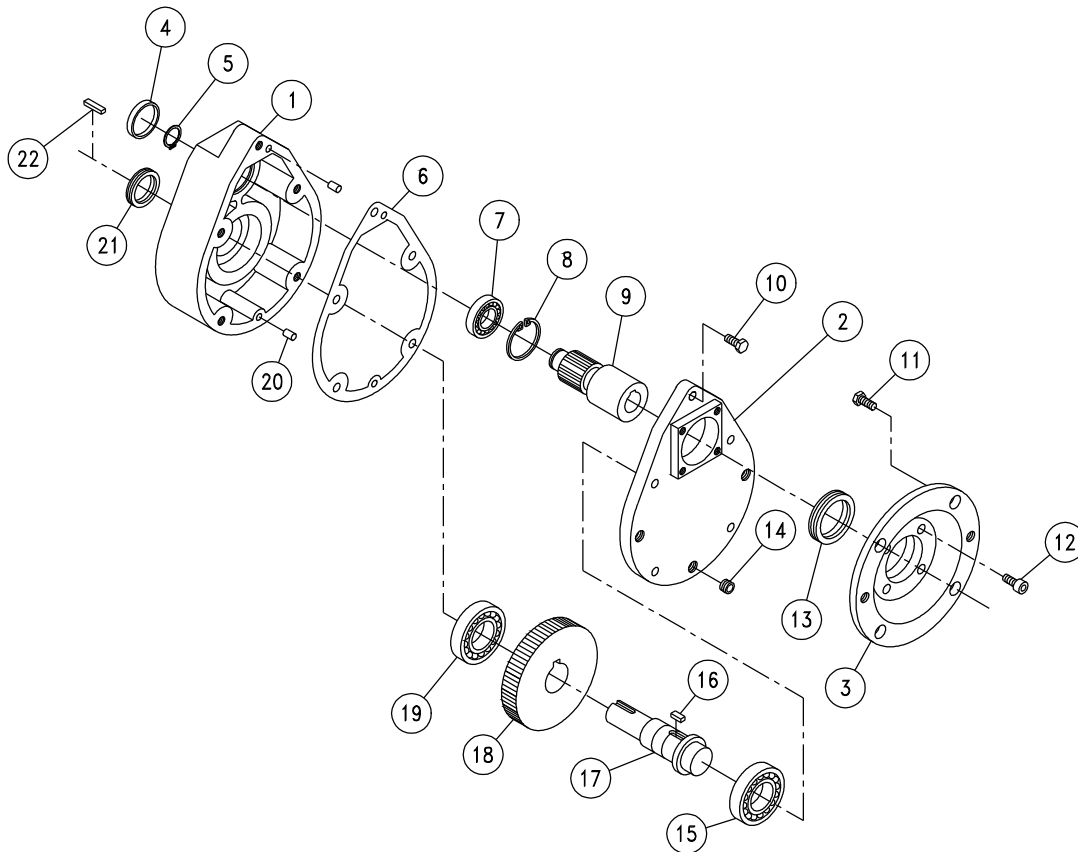

### SIZE 3 PARTS

