

STERLING
ELECTRIC, INC.

2000HG[®]

**R-SERIES IN-LINE HELICAL GEAR
REDUCER**

INSTALLATION AND MAINTENANCE MANUAL
September 15, 2009

2000HG IN-LINE HELICAL GEAR REDUCER INSTRUCTION MANUAL

SELECTION INFORMATION

Read ALL instructions prior to operating unit. Improper maintenance or operation may cause injury to personnel or reducer failure.

Written authorization from Sterling Electric is required to operate or use this unit in man lift or people moving devices.

Check to make certain application does not exceed the allowable load capacities published in the current catalog.

Buyer shall be solely responsible for determining the adequacy of the product for any and all uses to which buyer shall apply the product. The application by buyer shall not be subject to any implied warranty of fitness for a particular purpose. Information contained in this manual is considered correct at the time of publication and is subject to change without notice.

SAFETY ALERT

WARNING: For safety, purchaser or user should provide protective guards over all shaft extensions and any moving apparatus mounted thereon. The user is responsible for checking all applicable safety codes in his area and providing suitable guards. Failure to do so may result in bodily injury and/or damage to equipment.

WARNING: Hot oil or gear units can cause severe burns. Use extreme care when removing lubrication plugs and vents.

WARNING: Make certain that the power supply is disconnected before attempting to service or remove any components. Lock out the power supply and tag it to prevent unexpected application of power.

WARNING: Any brakes that are used in conjunction with this unit must be sized or positioned in such a way as to not subject the unit to loads beyond the catalog rating.

CAUTION: Test run unit to verify operation. If the unit tested is a prototype, that unit must be of current production.

CAUTION: If the unit cannot be located in a clear and dry area with access to adequate cooling air supply, then precautions must be taken to avoid the ingestion of contaminants such as water and the reduction in cooling ability due to exterior contaminants. Units located in confined spaces may require forced air-cooling.

IMPORTANT INFORMATION

In the event of the resale of any of the goods, in whatever form, Resellers/Buyers will include the following language in a conspicuous place and in a conspicuous manner in a written agreement covering such sale:

The manufacturer makes no warranty or representations, expressed or implied, by operation of law or otherwise, as to the merchantability or fitness for a particular purpose of the good sold hereunder. Buyer acknowledges that it alone has determined that the goods purchased hereunder will suitably meet the requirements of their intended use. In no event will manufacturer be liable for consequential, incidental or other damages.

Resellers/Buyers agree to also include this entire document including the warnings above in a conspicuous place and in a conspicuous manner in writing to instruct users on the safe usage of the product.

This instruction manual should be read together with all other printed information such as catalogs, supplied by Sterling Electric.

GENERAL OPERATION

1. Run the motor, which drives the unit, and check the direction of unit output rotation. Consult motor nameplates for instructions to reverse the direction of rotation.
2. Attaching the load: On direct-coupled installations, check shaft and coupling alignment between unit and loading mechanism. On chain/sprocket and belt/pulley installation, locate the sprocket or pulley as close to the oil seal as possible to minimize overhung load. Check to verify that the overhung load does not exceed specifications published in the catalog.
3. High momentum loads: If coasting to a stop is undesirable, a braking mechanism should be provided to the unit output or the driven mechanism.

CAUTION: The system of connected rotating parts must be free from critical speed, torsional or other type vibration, no matter how induced. The responsibility for this system analysis lies with the purchaser of the speed reducer.

INSTALLATION

1. Mount the unit using grade 5 or higher fasteners.
2. Mount the motor using the hardware supplied.

NOTE: With every C-face input gear reducer, Sterling Electric supplies the motor coupling half, a key, and a flexible coupling spider. In order to aid removal at a later date, anti-seize compound (not supplied) can be applied to the motor shaft and C-face pilot diameter.

NOTE: The motor coupling must be mounted with the supplied parts. Failure to use the supplied parts could void the Sterling Electric Warranty.

3. Remove any dirt or adhesive residue from the motor shaft.

4. The supplied key is to be placed in the motor keyway and should be located under the motor coupling.
- NOTE: the key is not to extend beyond the coupling bore on EITHER side.
5. The motor coupling is to be mounted on the motor shaft and is to be located accordingly to the dimension specified in **NEMA Adapter Coupling Location**.
 6. Tighten the setscrew located on the motor coupling.
 7. Place the flexible motor spider between the jaws of the motor coupling. Align the motor coupling so that the jaws on the reducer coupling mesh with the motor coupling. The motor shaft will extend into the bore of the reducer coupling. Secure the flanged motor to the C-face adapter with the supplied hardware unless otherwise specified by the motor manufacturer.

NEMA Adapter Coupling Location

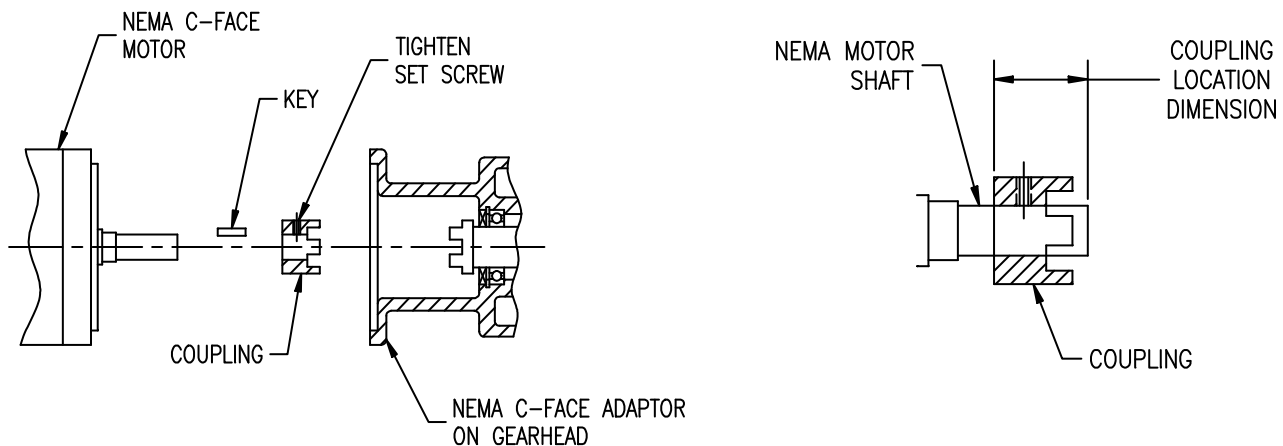

| NEMA Frame Size | *Coupling location Dimension (in) | | |
|-----------------|-----------------------------------|-------|--------|
| | R0402 | R0602 | R0702† |
| 56C | 1.79 | 1.90 | |
| 143TC / 145TC | 1.85 | 1.97 | 1.79 |
| 182TC / 184TC | 2.31 | 2.03 | 2.29 |
| 213TC / 215TC | | N/A** | N/A** |
| 254TC / 256TC | | | N/A** |

*Coupling Location Dimension Tolerance is $-0.0/+0.031$

** Quill style input, only special key required.

† No special key required on R0702.

8. For shipment, pipe plugs are installed in the unit and a vent plug is packed separately. After mounting the unit in position, remove the appropriate pipe plug and install the vent plug in the location shown in the chart under **LUBRICATION**. Failure to vent the unit can cause premature seal wear or loss of seal and oil. These conditions are not covered by warranty. Check for correct oil level. Contact the factory for level and vent recommendations on non-standard mounting positions.

WARNING: Prior to startup, verify that the unit is filled with the proper amount of oil based on the mounting position shown in the **LUBRICATION** section. Failure to do so will void the warranty.

CAUTION: Do not operate the unit without making sure it contains the correct amount of oil. Do not overfill or underfill with oil, or injury to personnel, reducer or other equipment may result.

CAUTION: A unit cannot be used as an integral part of a machine superstructure which would impose additional loads on the unit other than those imposed by the torque being transmitted either through a shaft-mounted arrangement, and any shaft mounted power transmitting device. (e.g. sprockets, pulleys, couplings)

CAUTION: For safe operation and to maintain the unit warranty, when changing a factory installed fastener for any reason, it becomes the responsibility of the person making the change to properly account for fastener grade, thread engagement, load, tightening torque and the means of torque retention.

LUBRICATION

All standard helical gear reducers ordered from the factory are shipped with standard compounded lubricant and is good for ambient temperature ranges of 30° F to 104° F. Position M1 is considered standard.

CAUTION: Use of synthetics can cause problems if they are not compatible with the seals or the conventional lubes they replace.

CAUTION: If the ambient temperature will be outside the range for the lubricant installed at the factory, drain and refill the reducer with the proper viscosity lubricant prior to use.

RECOMMENDED LUBRICATION OILS

| <u>Mineral Oils</u> | | | |
|-----------------------|--------------------------------|--------------------------------|---------------------------------|
| Manufacturer | ISO Viscosity / AGMA No. | | |
| | 220 / 5EP | 320 / 6EP | 460 / 7EP |
| | Ambient Temperature Range | | |
| | -5 to 25 °C (23 to 77 °F) | 0 to 40 °C (32 to 104 °F) | 10 to 50 °C (50 to 122 °F) |
| Chevron USA, Inc. | Gear Compound EP220 | Gear Compound EP320 | Gear Compound EP460 |
| Exxon CO. USA | Spartan EP220 | Spartan EP320 | Spartan EP460 |
| Mobil Oil Co. | Mobilgear 630 | Mobilgear 632 | Mobilgear 634 |
| Shell Oil Co. | Omala 220 | Omala 320 | Omala 460 |
| <u>Synthetic Oils</u> | | | |
| Manufacturer | ISO Viscosity / AGMA No. | | |
| | 220 / 5EP | 320 / 6EP | 460 / 7EP |
| | Ambient Temperature Range | | |
| | -5 to 25 °C (23 to 77 °F) | 0 to 40 °C (32 to 104 °F) | 10 to 50 °C (50 to 122 °F) |
| Chevron USA, Inc. | Tegra Synthetic EP220 | Tegra Synthetic EP320 | Tegra Synthetic EP460 |
| Exxon CO. USA | Spartan SEP220 | Spartan SEP320 | Spartan SEP460 |
| Mobil Oil Co. | Mobilgear SHC630 | Mobilgear SHC632 | Mobilgear SHC 634 |
| Shell Oil Co. | Omala HD220 | Omala HD320 | Omala HD460 |
| Summit Industrial | Syngear SH-7220 | Syngear SH-7320 | Syngear SH-7460 |

OIL CAPACITIES (FLUID OUNCE)

| Mounting Position | Unit Size | | |
|-------------------|-----------|-------|-------|
| | R0402 | R0602 | R0702 |
| M1 | 25 | 51 | 87 |
| M2 | 25 | 61 | 103 |
| M3 | 25 | 54 | 93 |
| M4 | 25 | 64 | 110 |
| M5 | 48 | 64 | 106 |
| M6 | 48 | 91 | 163 |

16 fl oz = 1 pint
 2 pints = 1 quart
 4 quarts = 1 US gallon

MOUNTING POSITIONS

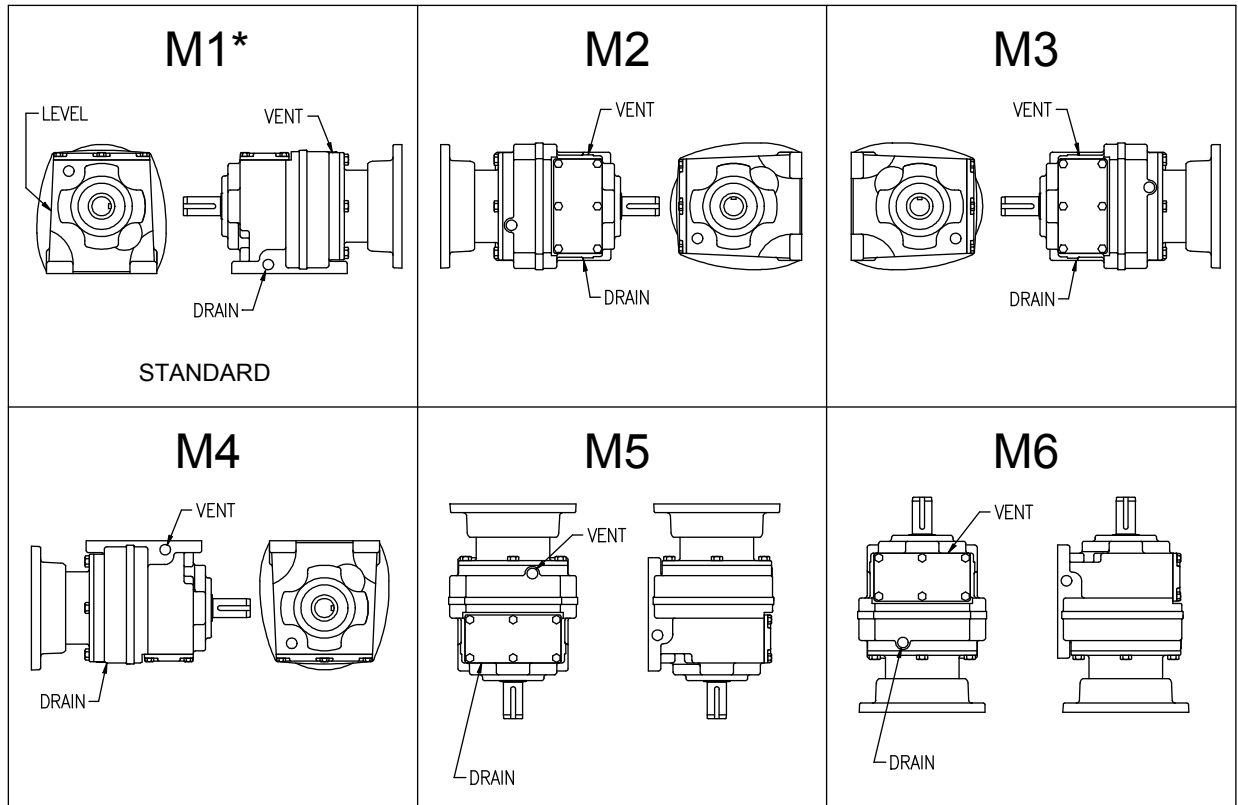

* NOTE: The unit is filled at the factory with the proper amount of oil for the standard mounting position M1. A level plug is provided for this position only so the unit can be checked for proper oil level prior to installation and start-up. All other mounting positions will require the oil level to be measured out prior to filling the unit based on the values in the table labeled **OIL CAPACITIES** above.

VENT PLUG LOCATION

Before putting the unit into operation, substitute the vent plug for the solid plug at the position desired. Arrows indicate the recommended vent plug locations

Change Intervals: Standard compounded lubricants should be changed every 10,000 operating hours. Synthetic lubricants should be changed every 20,000 operating hours.

CAUTION: Oil should be changed more often if the unit is used in a severe environment. (*i.e. dusty, humid*)

CAUTION: In the Food and Drug Industry (including animal food), consult the lubrication supplier for recommendation of lubricants which are acceptable to the Food and Drug Administration and/or other authoritative bodies having jurisdiction.

MAINTENANCE

Your Sterling Electric unit has been tested and adjusted at the factory. Dismantling or replacement of components must be done by Sterling Electric to maintain the warranty.

Frequently check the oil level of the unit. If oil level is low, (refer to the vent and level position chart) add proper lubrication through the filler plug until it comes out the oil level plug.

Inspect vent plug often to insure it is clean and operating.

CAUTION: Mounting bolts should be routinely checked to ensure that the unit is firmly anchored for proper operation.

Seals: The Sterling Electric line of speed reducers utilizes premium quality Viton® seals which are the state-of-the-art in sealing technology. Seals are, however, a wear item and eventually need to be replaced. Replacement of the seals can be easily accomplished by following the steps below:

1. Remove the worn seal without damaging the shaft surface or the seal bore. This can be done by drilling a .062 diameter hole in the seal casing (being careful not to drill into the bearing behind the seal). Screw a #10 sheet metal screw into the hole and pry out the seal.
2. Clean the seal bore of sealant.
3. Before installing the new seal, use electrical tape to cover any keyways or sharp edges on the shaft to prevent seal lip damage.
4. Grease the seal lips with bearing grease and apply a sealant to the seal bore.
5. Slide the seal into the shaft being careful not to fold the inner lip over on any shaft steps.
6. Press the seal into its bore with a sleeve that presses on the seal casing, being careful to keep the seal square in its bore.

CLASS OF SERVICE

All capacity ratings are based on American Gear Manufacturers Association (AGMA) Standards. Load conditions must be within cataloged ratings published in the current Sterling Electric Catalog (available upon request).

LONG-TERM STORAGE (6 MONTHS UP)

Units must be stored indoors, in a dry, warm temperature.

Completely fill the unit with oil.

Rotate the input shaft so that the output shaft rotates at least one revolution per month.

Completely cover the input and output shaft with grease.

At the time of start up, drain the storage oil, install the breather, and fill to the proper oil level with correct lubricant for the operating condition.

WARRANTY (LIMITED)

The warranty will cover all of the parts in the gearmotor or reducer unit for 12 months from the date of shipment.

The warranty is only for parts and labor. In no event shall our liability exceed the original price of the unit, nor does it cover cost of on site repair, installation, or freight.

Contact the service department for a complete explanation as to the full warranty policies and conditions of sale.

All dimensions designs and specifications are subject to change without notice

SEAL AND BEARING SIZES

Input Bearings (Item #29)

| Unit Size | Bearing Part Number and Size | | | | |
|-----------|------------------------------|---------|---------|------------|--------------|
| | Series | OD (mm) | ID (mm) | Width (mm) | Sterling P/N |
| R0402 | 6207LLC3 | 72 | 35 | 17 | 400-0118-2 |
| R0602 | 6208LLC3 | 80 | 40 | 18 | 400-0171-9 |
| R0702** | 6211LLC3 | 100 | 55 | 21 | 400-0124-7 |

(Item #26)

| Unit Size | Bearing Part Number and Size | | | | |
|-----------|------------------------------|---------|---------|------------|--------------|
| | Series | OD (mm) | ID (mm) | Width (mm) | Sterling P/N |
| R0402 | 6305 | 62 | 25 | 17 | 400-0008-9 |
| R0602 | 6306 | 72 | 30 | 19 | 400-0022-4 |
| R0702** | 6307LLC3 | 80 | 35 | 21 | 400-0133-4 |

Intermediate Bearings (Item #17)

| Unit Size | Bearing Part Number and Size | | | | |
|-----------|------------------------------|---------|---------|------------|--------------|
| | Series | OD (mm) | ID (mm) | Width (mm) | Sterling P/N |
| R0402 | NJ203 | 40 | 17 | 12 | 400-0536-4 |
| R0602 | NJ204 | 47 | 20 | 14 | 400-0540-0 |
| R0702 | NJ305 | 62 | 25 | 17 | 400-0549-1 |

Output Bearings (Item #5)

| Unit Size | Bearing Part Number and Size | | | | |
|-----------|------------------------------|---------|---------|------------|--------------|
| | Series | OD (mm) | ID (mm) | Width (mm) | Sterling P/N |
| R0402 | 6206 | 62 | 30 | 16 | 400-0008-9 |
| R0602 | 6207 | 72 | 35 | 17 | 400-0009-7 |
| R0702 | 6308 | 90 | 40 | 23 | 400-0549-1 |

(Item #11)

| Unit Size | Bearing Part Number and Size | | | | |
|-----------|------------------------------|---------|---------|------------|--------------|
| | Series | OD (mm) | ID (mm) | Width (mm) | Sterling P/N |
| R0402 | 6204 | 20 | 47 | 14 | 400-0005-4 |
| R0602 | 6206 | 62 | 30 | 16 | 400-0008-9 |
| R0702 | 6207 | 72 | 35 | 17 | 400-0009-7 |

Input Seal

| Unit Size | Bearing Part Number and Size | | | |
|-----------|------------------------------|-----------|------------|--------------|
| | Shaft (mm) | Bore (mm) | Width (mm) | Sterling P/N |
| R0402* | 35 | 62 | 7 | 404-0350-0 |
| R0602 | 40 | 72 | 7 | 404-0362-8 |
| R0702** | 40 | 55 | 8 | 40403919 |

Output Seal

| Unit Size | Bearing Part Number and Size | | | |
|-----------|------------------------------|-----------|------------|--------------|
| | Shaft (mm) | Bore (mm) | Width (mm) | Sterling P/N |
| R0402 | 35 | 62 | 7 | 404-0350-0 |
| R0602 | 40 | 72 | 7 | 404-0362-8 |
| R0702 | 50 | 90 | 8 | 404-0280-0 |

* EARLY STYLE UNITS HAVE 55X72X10 SIZE INPUT SEALS (P/N 404-0351-9). CONTACT FACTORY WITH UNIT SERIAL NUMBER BEFORE ORDERING SEALS TO CONFIRM SIZE. EARLY UNITS CAN BE RETROFITTED WITH THE CURRENT SEAL AS LONG AS A DOUBLE SEALED BEARING IS USED LOC#27 AND THE SEAL IS PROPERLY LOCATED IN THE HOUSING. CONSULT FACTORY FOR DETAILS.

** EARLY R0702 210TC QUILL STYLE UNITS HAVE 40X55X8 SIZE INPUT SEALS (P/N 404-03391-9) AND INPUT BEARING SIZE 6013LLC3 FOR ITEM#29 AND BEARING SIZE 6307LLC3 FOR ITEM#26 (P/N 400-0124-7 AND 400-0133-4 RESPECTIVLY). BEFORE ORDERING SEALS AND BEARINGS CONFIRM SIZE. EARLY UNITS CANNOT BE RETROFITTED WITH THE CURRENT SEALS AND BEARINGS. CONSULT FACTORY FOR DETAILS.

DOUBLE REDUCTION UNIT

Parts List

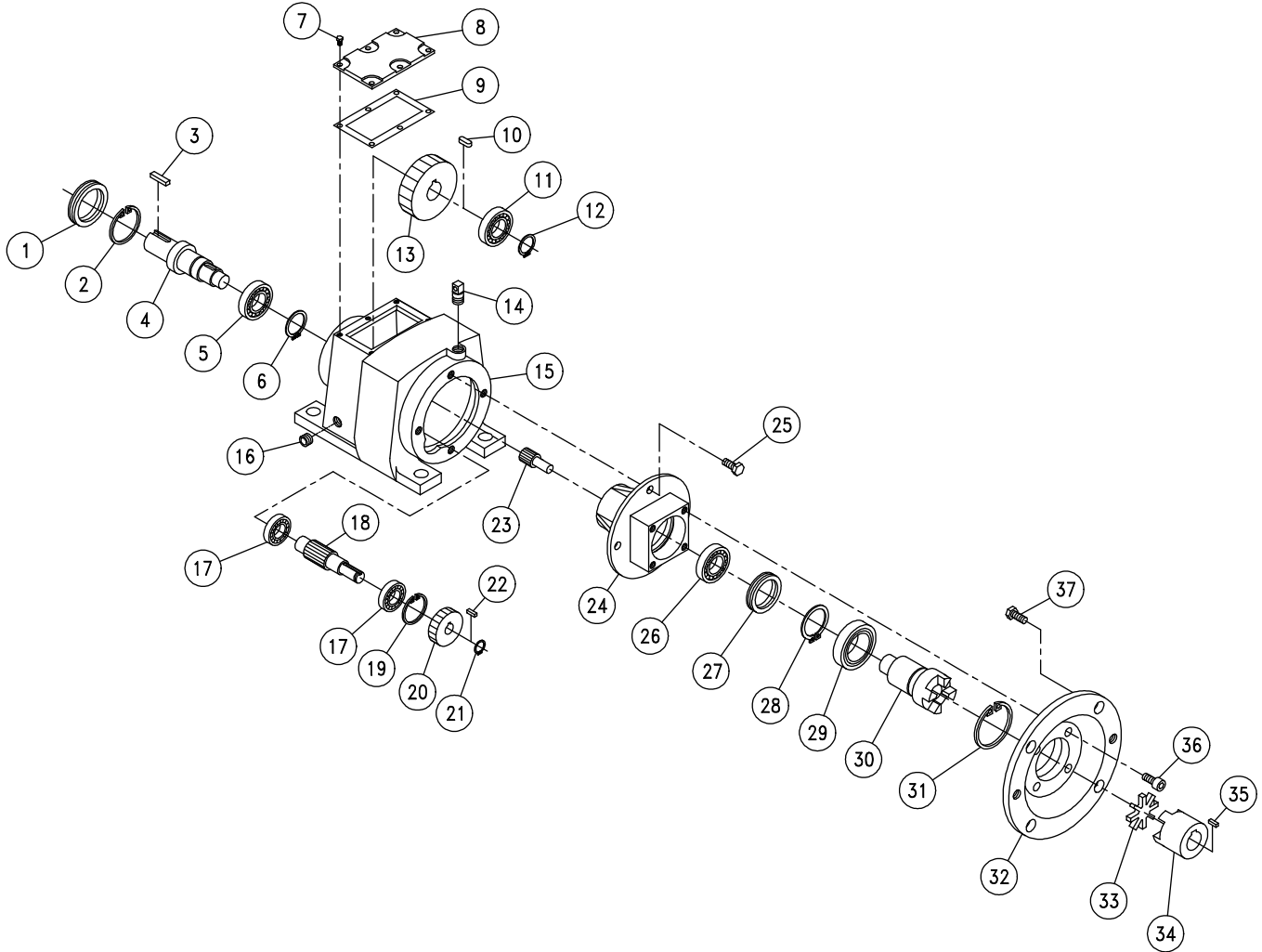

| Item No. | Description | Qty | Item No. | Description | Qty | Item No. | Description | Qty |
|----------|--------------------|-----|----------|----------------------------|-----|----------|----------------------------|-----|
| 1 | Output Seal | 1 | 14 | Breather / Vent | 1 | 27 | Input Seal | 1 |
| 2 | Internal Snap Ring | 1 | 15 | Gear Case Housing | 1 | 28 | External Snap Ring | 1 |
| 3 | Output Key | 1 | 16 | NPT Plug | 3 | 29 | Double Sealed Ball Bearing | 1 |
| 4 | Output Shaft | 1 | 17 | Cylindrical Roller Bearing | 2 | 30 | Input Shaft | 1 |
| 5 | Ball Bearing | 1 | 18 | Final Pinion Shaft | 1 | 31 | Internal Snap Ring | 1 |
| 6 | External Snap Ring | 1 | 19 | Internal Snap Ring | 1 | 32 | Input Motor Flange | 1 |
| 7 | Hex Head Screw | 6 | 20 | Primary Gear | 1 | 33 | Coupling Spider | 1 |
| 8 | Cover Plate | 1 | 21 | External Snap Ring | 1 | 34 | Motor Coupling Half | 1 |
| 9 | Cover Plate Gasket | 1 | 22 | Key | 1 | 35 | Motor Coupling Key | 1 |
| 10 | Key | 1 | 23 | Primary Pinion | 1 | 36 | Socket Head Screw | 4 |
| 11 | Ball Bearing | 1 | 24 | Input Adapter | 1 | 37 | Hex Head Bolt | 4 |
| 12 | External Snap Ring | 1 | 25 | Hex Head Screw | 4 | | | |
| 13 | Final Gear | 1 | 26 | Ball Bearing | 1 | | | |

NOTES: REPLACEMENT GEARS ARE AVAILABLE IN SETS ONLY. FOR EXAMPLE, A FINAL GEAR KIT WILL CONTAIN THE FINAL GEAR AND FINAL PINION SHAFT. A PRIMARY GEAR KIT WILL CONTAIN A PRIMARY GEAR AND A PRIMARY PINION. CONSULT FACTORY FOR PART NUMBERS.

Indianapolis, Indiana (800) 866-7973
Hamilton, Ontario (800) 809-0330

e-mail: sales@sterlingelectric.com
www.sterlingelectric.com